



A Cut Above

Using the Knew Concepts Precision Saw Frame with Advanced Screw Tensioning

US Patent #8,347,513

V4.0

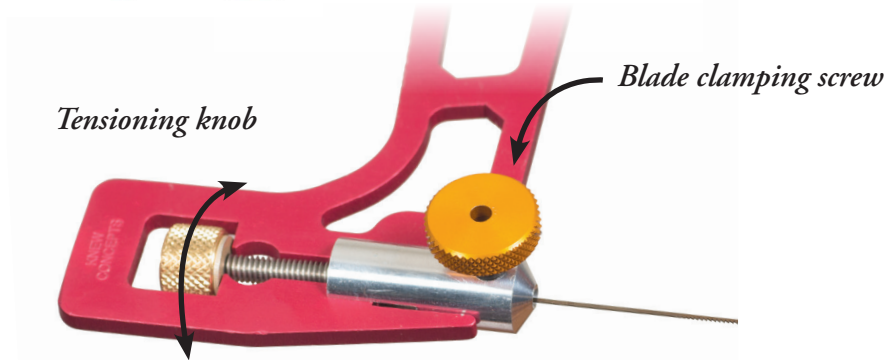
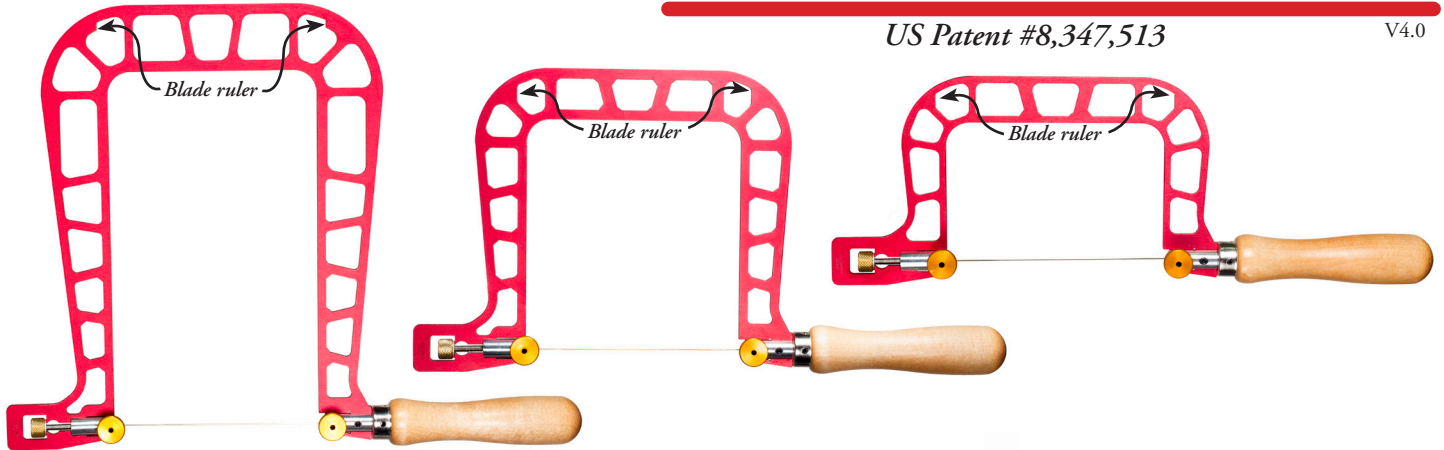

Loosen the tension EVERY time you take a blade out, before placing a new blade in both blade clamps. It usually needs to be loosened two or three turns. Too much loosening will allow the blade clamp to fall out of the saw. Refer to picture above for reassembly order. Please try not to do it again.

Tensioning

The knurled brass knob is the tensioning mechanism.

- To increase tension, screw it 'in' towards the clamp.
- To release tension, screw it 'out' away from the clamp.

The knob must be unscrewed slightly to reset tension during every blade change. After clamping a new blade, twist the knob to return tension to desired level.

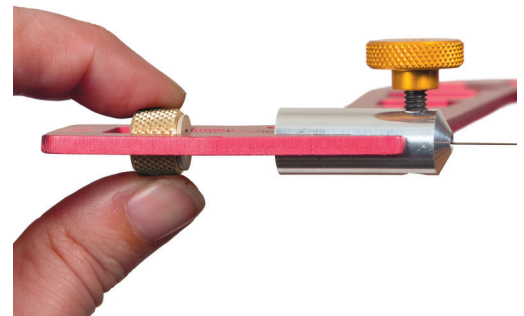

Check the Saw Blade length

Before sawing, check the length of the saw blades.

The standard length for jewelers/fret saw blades is 5 1/8" (130mm)

There is a blade ruler built into the spine of your saw.

There are flat spots in the windows along the spine that are exactly 5 1/8" apart, as indicated in the photos above. Lay the blade between those two flat spots. If it's the same length, it's the right size.

- If the blades are too long, use wire cutters to shorten the blades.
- Blades that are shorter than standard will not work.

Blade Installation

1. **Insert blade in the upper holder** and tighten the clamp screw.

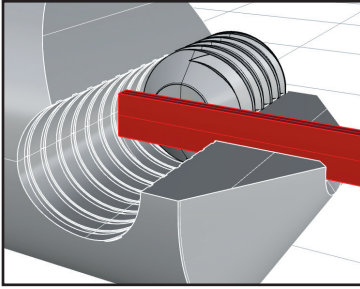

End of blade fully inserted

The end of the blade is stopped by touching the back wall at the rear of the blade hole. *(The blade has been colored red to make it easier to see.)*

As you can see in this cut-away view, the blade is gripped at the very end.

The tension must be relaxed before inserting a blade so that the blade will go all the way to the back wall for proper grip.

2. **Loosen the adjusting knob at the top at least one full turn to lower the holder***

**Take care: Over-loosening the top blade holder can cause the components to become separated.*

3. If you are piercing, thread the blade through the hole in the metal.

4. Check for proper blade clamping

After clamping the blade in the upper clamp, the loose end of the blade should extend just beyond the lower anvil screw. This makes sure that the blade will be clamped properly before tensioning. If the blade is 5 1/8" long, but does not extend as shown, loosen the tension more, and reseat the blade in the upper clamp.

End of blade should extend just past end of anvil screw.

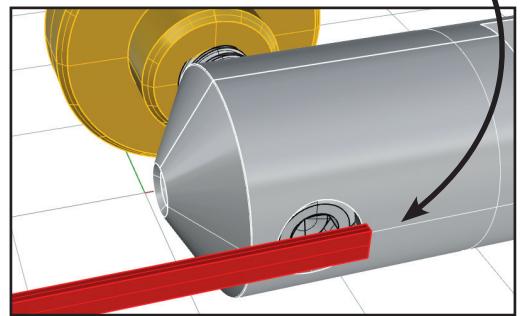

5. Push the upper holder upwards.

This makes it easier to insert the blade into the lower clamp. Once the blade is inserted, push the blade clamp back down towards the handle.

6. **The blade will bow slightly when the ends of the blade contact the bottoms of the holes.**

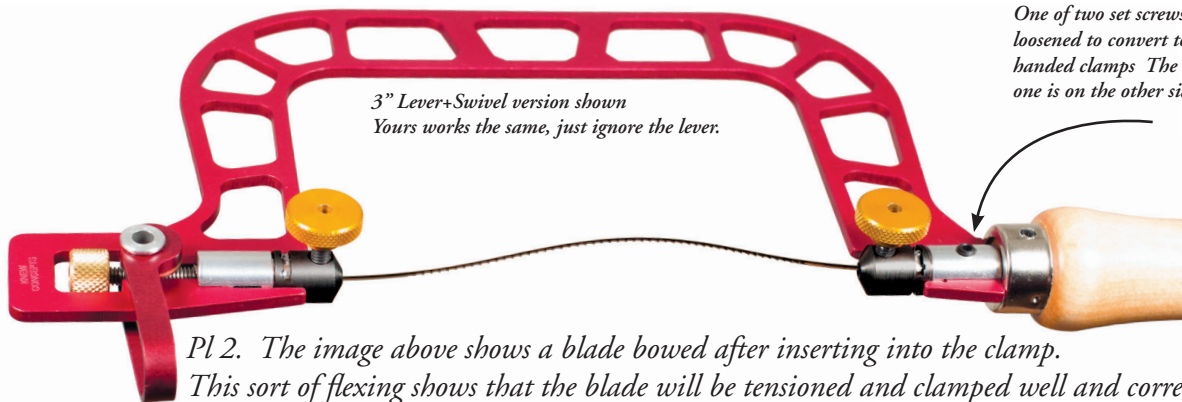

*3" Lever+Swivel version shown
Yours works the same, just ignore the lever.*

One of two set screws to be loosened to convert to left handed clamps. The other one is on the other side.

*Pl 2. The image above shows a blade bowed after inserting into the clamp.
This sort of flexing shows that the blade will be tensioned and clamped well and correctly.*

7. **Tighten the clamp screw into the blade holder.**

Tensioning the blade:

Tension the blade by turning the adjusting knob clockwise.

Flick the blade with your finger — a taut blade “sings”.

Installing the next blade:

Remember to loosen the tension knob, which lowers the blade clamp. This is essential, so that the clamp screw can grab the blade fully.

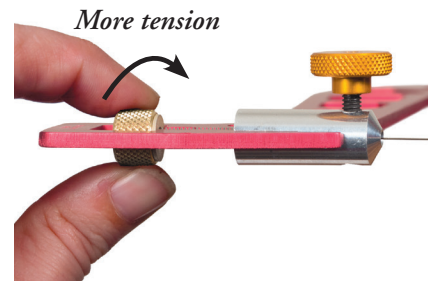

More tension

Tips & Troubleshooting

There are a variety of troubleshooting videos at www.knewconcepts.com. Look for the 'videos' link.

If you are unable to get the blade tight,

Make sure that you remembered to loosen the tension, so that the tips of the blade will touch the ends of the holes. Also, check the length of the blade. It may be too long or short; standard length is 5 1/8".

- There are blade rulers built into the frame, see page 1.

Tightening means to turn a screw clock-wise.

Some people like to remember this by saying, "Lefty-Loosey, Righty-Tighty"

If the blade breaks before you start sawing:

- The blade is over-tightened. Don't set the tension quite so high on the next blade.
Knew Concepts saws are the stiffest ever made. Your saw is stronger than the blade, and is capable of tearing it apart if you dial in too much tension. How much tension a blade will take varies by brand. You will have to experiment to see how much your brand will take, and how tight you like them.

If the blades pull out of the holder prematurely, unscrew the knob, and check for broken bits of saw blades inside the hole. If you really have trouble, unscrew the clamping knob entirely, and blow out the clamp socket with compressed air through the blade hole. Then reinstall the clamping knob. Do not remove or adjust the anvil screw.

- "Canned Air" sold for computer cleaning works well for this. Use the straw.

Changing clamp knob orientation for left handed use

If you prefer to have the clamp knobs on the opposite side of the frame:

- Unscrew the brass tension knob from the upper blade clamp.
- Remove the upper blade clamp, flip it over so that the clamping knob is on the other side, and reinstall.
- Replace the brass tension knob.
- Use 5/64" allen wrench to loosen the set screws that hold the lower blade clamp in place.
(The two sockets closest to the handle. Indicated with an arrow in Pl 2, opposite page.)
- Flip the blade clamp over so that the clamping knob is on the other side.
- Reinstall lower blade clamp. (Make sure the lower clamp re-seats all the way down against the handle.)
- Re-tighten the two set screws loosened previously.
- Replace blade, and adjust brass tension knob for desired tension.

Correct alignment

This cut-away provides a visual of what is going on inside the blade clamp. When properly aligned, the blade will go in easily, and when the clamp knob is tightened, the blade will stay straight.

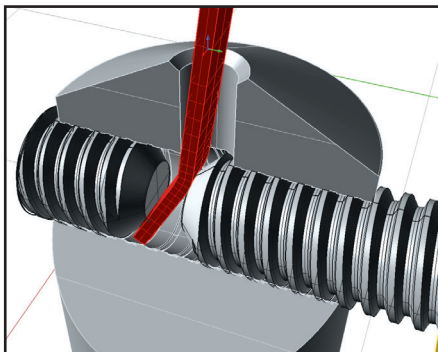

Anvil screw out too far

This shows what usually causes bent or broken ends.

- Use 5/64" Allen wrench to adjust anvil screw for correct alignment.

The goal is to get the blade centered in the throat of the clamp, as in the correctly aligned cut-away view.

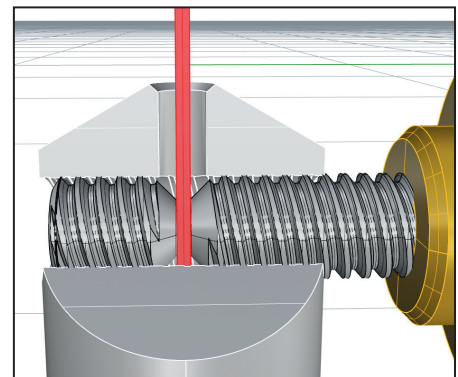

Precision Work Requires Precision Tools



About Knew Concepts and Lee Marshall

The “Back Story” of this Saw Frame

In 2005, before Knew Concepts was even a gleam in his eye, Lee Marshall developed the second version of his precision saw guide for making blanking dies for jewelers. Silversmith Cynthia Eid found that she *really* enjoyed the saw developed for that system, because of the blade tensioning mechanism. She started using that saw for *all* of her sawing, and she kept telling Lee that he needed to develop the saw as a “stand-alone” tool. After about 3 years, the irresistible force overcame the immovable object, and the rest is history.

Knew Concepts started in 2008, as a sort of ‘retirement project’ for Lee. The idea was to putter with these little red saws to pay the rent on his small shop space. That lasted about 6 months. It turned out he’d invented the better mousetrap, and we were off to the races; having more fun than any of us ever thought to.

After taking the sawing world by storm, Lee passed away in 2017. The company continues on, with the same people, and the same goal: helping you pursue your work and your passion for well-made tools that bring pleasure to the task. Our products may feel luxurious to use, but they are never extravagant, as they are designed and made with you and your needs foremost and are made to last a lifetime. Reward yourself for all of your hard work!

About this Saw Frame

THIS IS THE LIGHTEST, MOST RIGID FRAME ON THE MARKET!

Weight:

Aluminum three inch deep frame weighs 3.4 ounces/96.4 grams.

Titanium* three inch deep frame weighs 4.0 ounces/113.36 grams.

**Titanium is much stronger than aluminum, though slightly heavier.*

Rigidity:

The rigidity of the frame determines how much blade flex occurs.

A weak frame increases blade flex, increasing blade breakage.

A weak frame reduces your control of the blade.

**Have a question? Visit WWW.KNEWCONCEPTS.COM
or contact us at info@knewconcepts.com**